



GENERAL

The Model SM7B dynamic microphone has a smooth, flat, wide-range frequency response appropriate for music and speech in all professional audio applications. It features excellent shielding against electromagnetic hum generated by computer monitors, neon lights, and other electrical devices. The SM7B has been updated from earlier models with an improved bracket design that offers greater stability. In addition to its standard windscreen, it also includes the A7WS windscreen for close-talk applications.

Features

- Flat, wide-range frequency response for clean and natural reproduction of both music and speech
- Switchable bass rolloff and mid-range emphasis (presence boost) settings
- Shielded against broadband interference from computer monitors and other electrical devices—excellent rejection of electromagnetic hum
- Internal “air suspension” shock isolation virtually eliminates mechanical noise transmission
- A7WS windscreen included for close-up vocals or narration
- Swiveling bracket with integrated stand adapter for easy mounting and precise microphone positioning
- Cardioid polar pattern, uniform with frequency and symmetrical about axis, to provide maximum rejection and minimum coloration of off-axis sound
- Rugged construction and excellent cartridge protection for outstanding reliability

APPLICATIONS

The exceptional performance and unique features of the SM7B make it the outstanding choice for such applications as:

- Recording Studio—Instrumental and Vocal
- Location Recording
- Motion Picture and Television Scoring
- Television Talk Shows and News Desks
- Radio Announcing and Production
- Narration

WINDSCREEN

Use the standard windscreen for general voice and instrumental applications. Use the supplied A7WS windscreen for close-talk applications, such as voice overs or radio announcements, as it offers maximum protection from plosive breath noise and creates a warmer, more intimate sound.

To install the A7WS, follow these instructions:

1. To avoid tearing the windscreen during removal, grip it from the plastic ring and the base and remove by gently pulling and twisting.

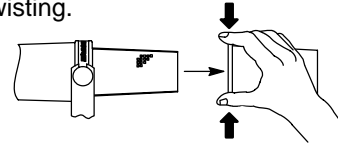

2. If desired, adhere the supplied velcro strips around the microphone grille, approximately one inch from the base of the grille (as shown above) to hold new windscreen in place.



3. Install the A7WS windscreen by stretching over the velcro strips, then squeezing at the base of the windscreen to adhere to the velcro. No velcro strip inside the windscreen is needed, as the windscreen itself adheres to the velcro. To remove, grip at the base of the windscreen and pull while twisting.

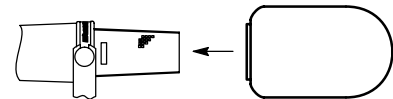

MOUNTING INSTRUCTIONS

The SM7B can be mounted on a microphone stand or hung from a boom. It is shipped in the boom mounting configuration (see Figure 1). To set up the SM7B in the microphone stand mounting configuration (see Figure 2), proceed as follows:

1. Remove tightening nuts on the sides (see Figure 7).
2. Remove the fitted washers, the lock washers, the outer brass washers, and the brass sleeves.
3. Slide the bracket off the microphone. Be careful not to lose the washers still on the microphone.
4. Invert and rotate the bracket. Slide it back onto the bolts over the brass and plastic washers still on the microphone. The bracket should fit so the XLR connector faces the rear of the microphone, and the Shure logo on the back of the microphone is right-side up.
5. Replace the brass sleeves. Be sure they are seated properly within the inner washers.
6. Replace the outer brass washers, the lock washers and the fitted washers.
7. Replace the tightening nuts and tighten the microphone at the desired angle.

NOTE: If the tightening nuts do not hold the microphone in position, one or both of the brass sleeves may not be properly seated within all the washers.

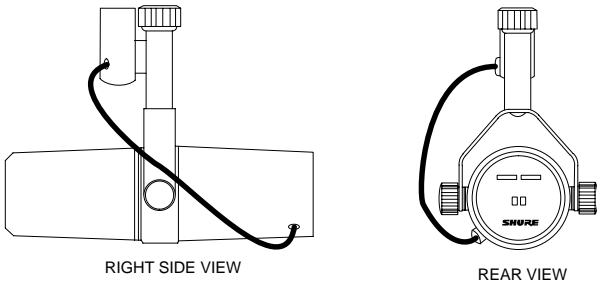

RIGHT SIDE VIEW REAR VIEW
BOOM MOUNTING CONFIGURATION
FIGURE 1

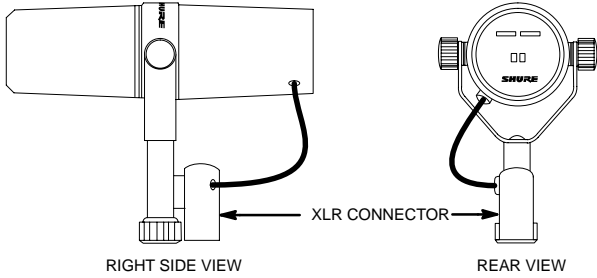

RIGHT SIDE VIEW REAR VIEW
MICROPHONE STAND MOUNTING CONFIGURATION
FIGURE 2

RESPONSE SELECTOR SWITCH COVER

Use the supplied cover plate to prevent accidental change of response setting.

SPECIFICATIONS

Type
Dynamic

Frequency Response
50 to 20,000 Hz (see Figure 3)

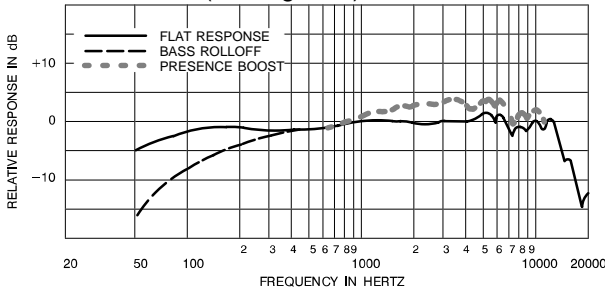

TYPICAL FREQUENCY RESPONSE
FIGURE 3

Polar Pattern

Cardioid (unidirectional). See Figure 4.

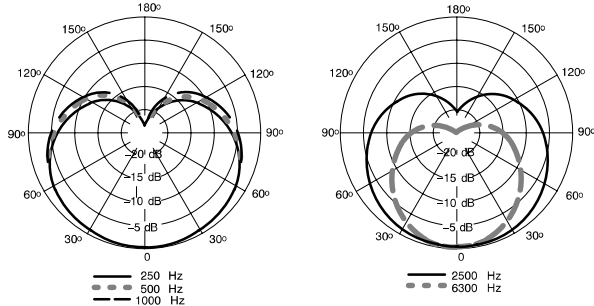

TYPICAL POLAR PATTERNS
FIGURE 4

Impedance

Microphone impedance rating is 150 Ω (150 Ω actual) for connection to microphone inputs rated at 19 to 300 ohms.

Polarity

Positive pressure on diaphragm produces positive voltage on pin 2 relative to pin 3.

Output Level (at 1,000 Hz)

Open Circuit Voltage* - 59.0 dB (1.12 mV)
*0 dB = 1 volt per Pascal

Electromagnetic Hum Sensitivity (Typical, Equivalent SPL/milliOersted)

60 Hz: 11 dB
500 Hz: 24 dB
1 kHz: 33 dB

Switches

Bass rolloff and mid-range emphasis: Slotted response selector switches. See Figure 3 for bass rolloff and mid-range emphasis (presence boost) response.

Cartridge Shock Mount

Internal air-suspension shock and vibration isolator.

Microphone Connector

Three-pin professional audio (XLR)

Swivel Assembly

Integrated, captive nut for ease of attachment to stand, fits 5/8 in.-27 thread.

Case

Dark gray enamel aluminum and steel case with dark gray foam windscreen.

Dimensions

See Figure 5.

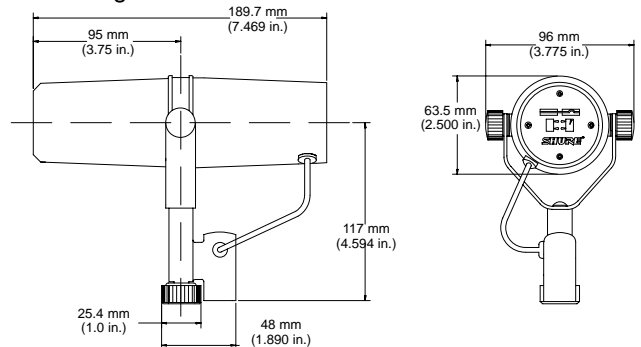

OVERALL DIMENSIONS
FIGURE 5

Net Weight

765.4 grams (1 lb, 11 oz)

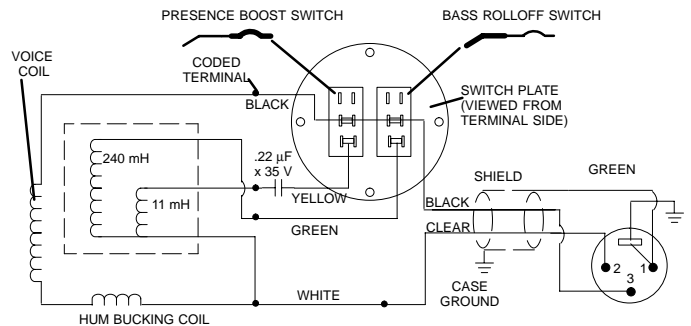

INTERNAL CONNECTIONS
FIGURE 6

Certification

Eligible to bear CE marking. Conforms to European EMC Directive 89/336/EEC. Meets applicable tests and performance criteria in European Standard EN 55103 (1996) parts 1 and 2, for residential (E1) and light industrial (E2) environments.

FURNISHED ACCESSORY

- Switch Cover Plate RPM602
- Close-Talk Windscreen A7WS

OPTIONAL ACCESSORIES

- Desk Stand S37A, S39A
- Cable and Plug Assembly (7.6m – 25 ft) C25F

REPLACEMENT PART

- Cartridge RPM106
- Windscreen RK345
- Nut/Washers RPM604

ARCHITECTS' SPECIFICATIONS

The microphone shall be a moving coil (dynamic) type with a frequency response of 50 to 20,000 Hz. The unit shall have a cardioid polar characteristic. The cancellation at the sides shall be approximately 6 dB and the cancellation at the rear shall be 15 to 20 dB. The microphone shall be low impedance with a rated impedance of 150 ohms for connection to microphone inputs rated at 19 to 300 ohms. The microphone output shall be -57.0 dB where 0 dB = 1 milliwatt per Pascal.

The microphone shall have two switches for controlling the frequency response. The first switch is a Bass Rolloff selector switch. One position of this switch provides a flat low frequency response and the second position provides a gradual low frequency rolloff. The second switch is the Mid-Range Emphasis (presence boost) switch. One position of this switch provides a flat mid-range frequency response and the second position raises the level of the mid-range frequency response. The microphone shall be equipped with an integral swivel assembly suitable for mounting on a stand with a 5/8 in-27 thread.

The overall dimensions shall be 189.7 mm (7.469 in.) in length, 148 mm (5.812 in.) in height, and 96 mm (3.775 in.) in width. The weight of the microphone shall be 765.4 g (1 lb., 11 oz.)

The microphone shall be the Shure Model SM7B or equivalent.

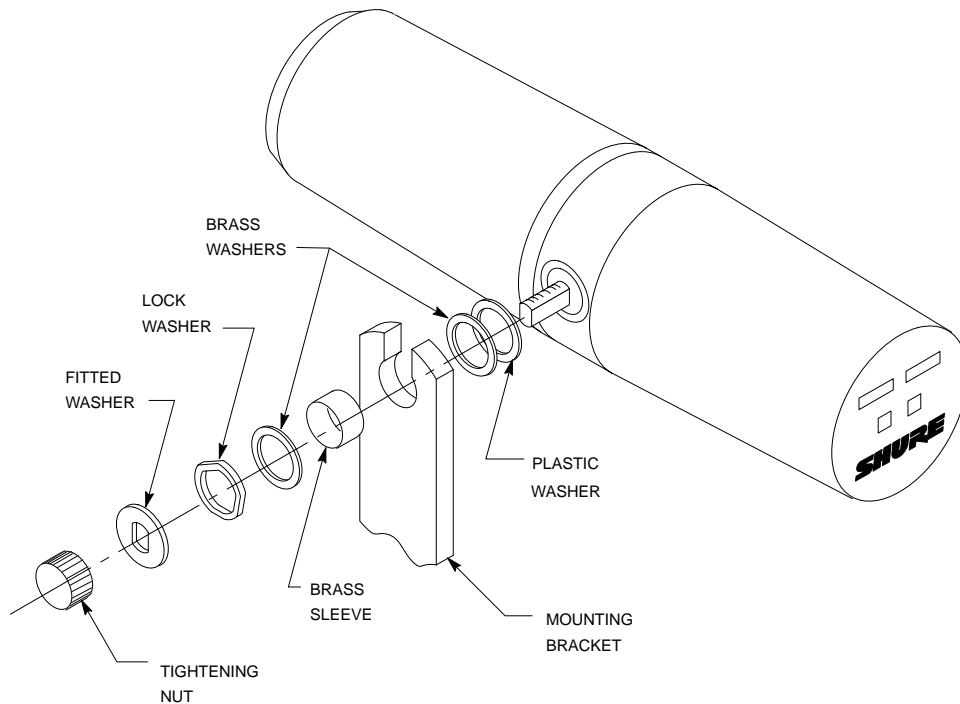

MOUNTING ASSEMBLY – EXPLODED VIEW
FIGURE 7