

361B Mixer/Power Amplifier

361B



Features:

- Two Channel Mixer/Power Amplifier
- Full Range of Plug-In Accessories
- All Solid-State Design
- Transformerless Operation With 4 to 16 Ohm Loads
- Easily Installed 70-Volt Output Transformer
- Volume Compressor Optional
- 18 Watts of Power
- Frequency Response ± 1 DB, 20-20,000 CPS
- Plug-In Microphone Preamplifier, Equalized Amplifier (Phono), or Line Transformer
- Compact, Rugged Design
- Minimum Heat Generation
- Extremely Low Noise Figure
- Shelf or Rack Mounted (With Mounting Frame)

MIXER/POWER AMPLIFIER FOR: PAGING, VOICE AND MUSIC SYSTEMS SCHOOLS — THEATERS — HOTELS — CLUBS — FACTORIES OFFICES — CHURCHES

The Altec 361B mixer/power amplifier is a solid-state unit designed to control, mix and amplify two independent input signals, providing 18 watts of power to 4-16 ohm loads. The 361B mixer/power amplifier provides complete versatility to meet the demands of the diverse sound distribution problems which confront the sound engineer. Equally effective with any complement of accessories, the 361B can be tailored to the needs of the small complex installations, providing professional sound at moderate cost.

Without accessories, one input may be used for a ceramic phono pick-up or a high-impedance announce microphone while the other input may be used for any high-impedance high level device such as a radio tuner or a tape machine. Either input may be used for low-impedance 600-ohm sources.

With accessories — plug-in devices such as the 1578A or 1588A microphone preamplifier, the 1579A equalized phono amplifier, or the 15095 transformer — the mixer/power amplifier will accommodate low-impedance microphones, magnetic pick-ups, balanced or unbalanced low-impedance lines, etc. The 16660 line transformer accessory provides the standard 70-volt speaker distribution system. This transformer is designed to mount on the rear of the amplifier in minutes with solderless inter-connecting links and provides a 70-volt isolated output. The performance of this transformer is such that in excess of 18 watts at less than 2% distortion is available from 40 cycles to above 15,000 cycles. An additional accessory, the 14678A volume compressor assembly can be mounted on the rear panel where a socket has been provided for proper connection to the amplifier circuitry.

The power supply of the 361B mixer/power amplifier is equipped with self-resetting circuit breakers in the primary and the secondary transistor supply circuits to provide maximum component protection in the event of inadvertent speaker line short circuit, inadequate ventilation or other abnormal operating conditions.

The Altec 361B mixer/amplifier measures only 4 $\frac{3}{4}$ " high, 13 $\frac{1}{8}$ " wide and 8 $\frac{1}{8}$ " deep. The front panel is functionally designed and includes two-color appearance with control knobs having brushed aluminum inserts. Overall illumination of the front panel is provided by indirect means. For rack mounting applications the Altec 14965 rack mount assembly permits the 361B to be rack mounted using only 5 $\frac{1}{4}$ " of vertical rack space.



A Division of BSPV Ling Altec, Inc.

1515 S. Manchester Ave., Anaheim, Calif.
New York

INPUT ACCESSORIES

The plug-in accessories for the input circuits of the mixer/power amplifier are carefully designed units, using solid-state circuitry for rugged dependable operation and high quality performance. These plug-in accessories make the proper input circuit instantly available for rapid installation permitting use of a wide range of input devices. Sockets on the rear of the mixer/power amplifier are pre-wired for the proper operating voltage and circuit connections, allowing the various plug-in accessories to be interchanged without rewiring, circuit or component changes and to be used in any combination to match *properly*, all commonly used input devices. The following descriptions are provided to explain the functions and performance of each of them.

1578A MICROPHONE PREAMPLIFIER

The 1578A microphone preamplifier is designed with a gain of 33.5 db. Sensitivity is 43 millivolts rms for an output of +8 dbm. Frequency response is ± 0.5 db, 20-20,000 cps, or, ± 1.5 db, 15-50,000 cps. Source impedance is 150 ohms nominal, usable 30 to 20,000 ohms. Equivalent input noise is -122 dbm. The 1578A requires 12 vdc at 13 ma. The 1578A microphone preamplifier may be used with any high quality low-impedance microphone.

1588A MICROPHONE PREAMPLIFIER

The 1588A Transistor Preamplifier has a transformer-isolated input and is designed for use with microphones. The 1588A has a gain of 33.5 db and a frequency response of ± 1 db from 30 to 30,000 cycles. Source impedance is 150/250 ohms and the load impedance is 600 ohms. The 1588A is encased in mu-metal providing effective magnetic shielding for the input transformer of 90 db. The equivalent input noise level is -122 dbm. Physically and electrically, the 1588A is interchangeable with the 1578A Preamplifier.

1579A PHONO EQUALIZED PREAMPLIFIER

The 1579A phono equalized preamplifier is specially designed for magnetic phono pick-ups to meet the RIAA standard. Sensitivity is 5 millivolts for 70 millivolt output at 1 kc. Output is +8 dbm at less than 0.5% thd (total harmonic distortion). Input impedance is 47,000 ohms and the power required is 12 vdc at 11 ma. Figure 1 illustrates the

performance of the 1579A as referenced to the RIAA standard.

15095 LINE TRANSFORMER

The 15095 line transformer may be used as a bridging transformer for bridging a balanced 600 ohm line. The 15095 has 30 db of electro-magnetic shielding and a frequency response of ± 1 db, 30-20,000 cps. The 15095 line transformer may also be used to perform a terminating function rather than a bridging function by the addition of a proper terminating resistor at the input of the mixer/power amplifier.

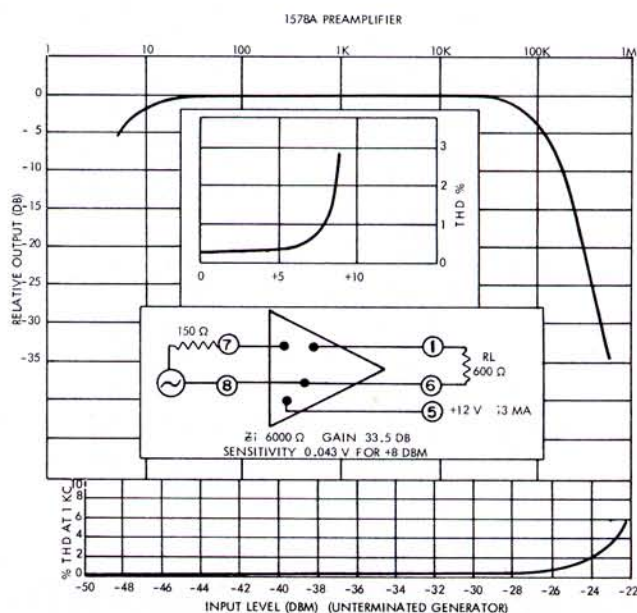
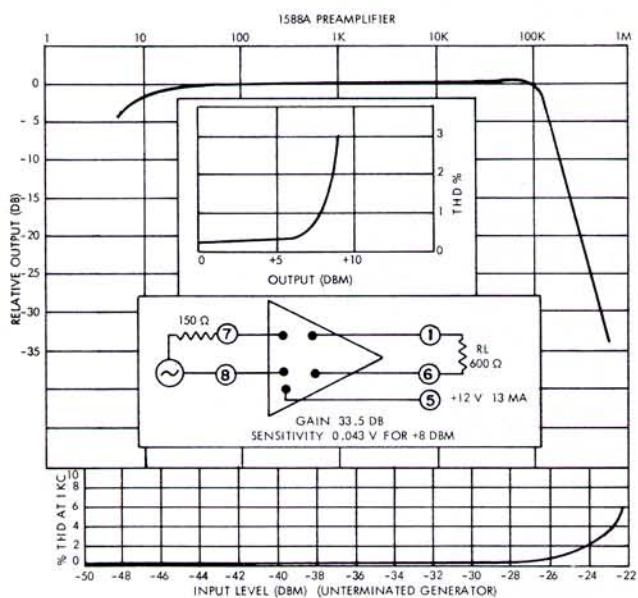
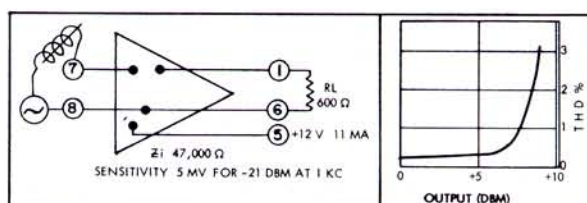
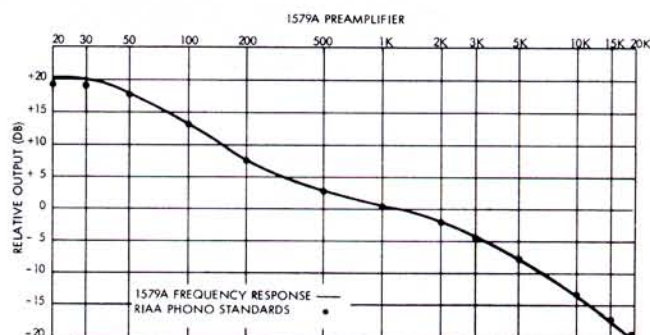

ADDITIONAL ACCESSORIES 16660 OUTPUT TRANSFORMER

The output of the 361B mixer/power amplifier is transformerless and, therefore, one side of the output is at ground potential. The Altec 16660 70-volt output transformer has been provided for standard speaker distribution systems where a balanced line is required. The 16660 transformer mounts on the rear of the 361B mixer/amplifier without soldering and no additional hardware other than that supplied with the amplifier is required. The performance of this transformer is such that in excess of 18 watts at less than 2% distortion is available from 40 cycles to above 15,000 cycles.



14965 RACK MOUNTING ASSEMBLY

When rack mounting of the 361B mixer/power amplifier is desired, the 14965 rack mounting assembly has been provided as an accessory. The rack mounting assembly includes a front panel for the amplifier which maintains the pleasing appearance and allows the rack to be pressure ventilated if associated equipment requires it. Rack mounted, the 361B will occupy 5 1/4" of vertical rack space and the front panel is painted Altec Green.

14678A VOLUME COMPRESSOR ASSEMBLY

The volume compressor is rear mounted and is connected to the circuitry of the 361B mixer/power amplifier by means of a six-pin plug attached to the compressor assembly. A knob on the rear of the compressor assembly controls the compression threshold and is adjustable in steps of 2, 4, 8, 16 and off. The numbers correspond to approximate power output in watts. The compressor is rapid acting having an attack time of 10 milliseconds and has a compression ratio above threshold of better than five to one.

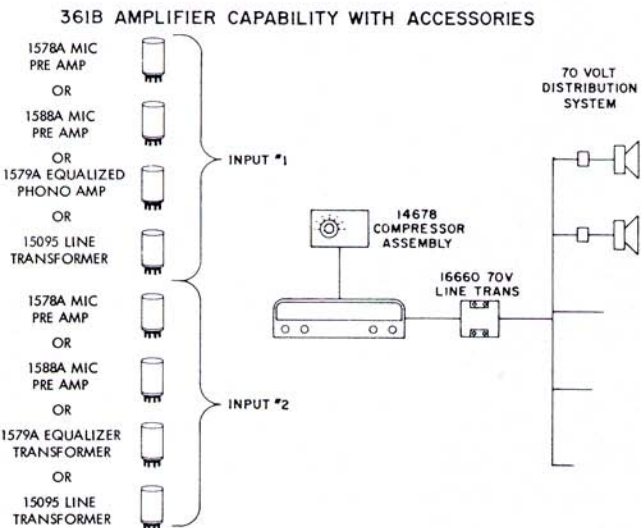

361B AMPLIFIER CAPABILITY WITHOUT ACCESSORIES

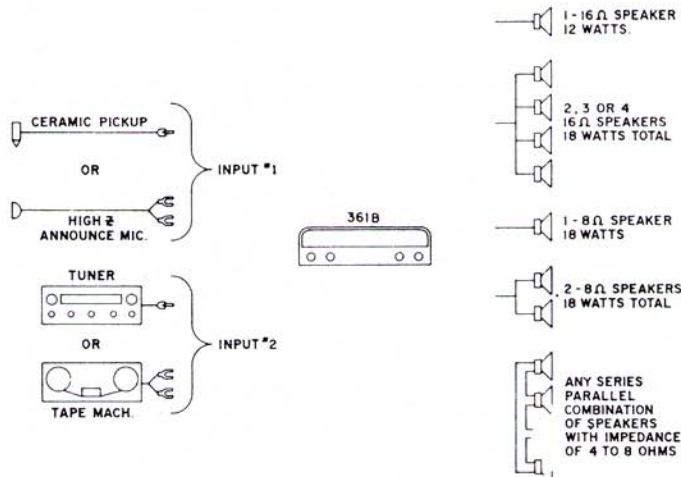

Type:	Two channel transistor mixer/power amplifier with plug-in options.	1 selector switch for high-impedance microphone or ceramic phono pickup on rear panel*.
Gain:	100 db into high-impedance microphone input. *117 db with 1578A plug-in microphone pre-amplifier. *67 db with 15095 plug-in transformer bridging 600-ohm line.	1 balance control, internal.
Input Sensitivity:	700 mv rms 18 watts output, ceramic phono pick-up. *500 mv rms for 18 watts output, tuner input. *0.5 mv (1 kc) for 18 watts output, with 1579A equalized plug-in amplifier for magnetic phono pick-up.	Power Supply: 117 volts, 50-60 cps (10 watts at zero signal, 28 watts at 1/3 output, and 42 watts at full power).
Power Output:	25 watts mid-band at less than 2% thd, 4 to 6 ohm loads and 70-volt line, 18 watts at less than 2% thd, 30 to 15,000 cps, 4 to 8 ohm load, 18 watts at less than 2% thd, 40 to 15,000 cps, 70-v line, 12 watts at less than 2% thd, 45 to 12,000 cps, 16 ohm load.	Dimensions: 4 3/4" H x 13 3/4" W x 8 1/4" D. Color: Altec Green. Weight: 10 lbs.
Frequency Response:	±1 db from 10 to 20,000 cps.	Accessories: 1578A transistor preamplifier, plug-in (microphone). 1579A equalized transistor preamplifier, plug-in (magnetic phono). 1588A transistor preamplifier, plug-in, transformer-isolated input (microphone). 14678 Compressor assembly and 14722 bracket, plug-in connection. 15095 transformer, plug-in (high-level balanced line to mixer). 16660 transformer for 70-volt line (mounts internally from rear with 6 screws for mechanical and electrical connections).
Input Impedance:	Direct input to mixer pots, 600 ohms nominal (unbalanced), Tuner input, 30,000 ohms.	*Indicates the ceramic phono-hi Z Microphone switch, which functions as a high-low gain switch when plug-in accessories are used, is in the HI Z MIC position. Approximately 5.5 db of attenuation is available when the switch is in the CER PHONO position.
Source Impedance:	20,000 ohms high-impedance microphone input (channel 1 only), Ceramic phono input (channel 1 only), Up to 50,000 ohms, tuner input (channel 2 only), 150 ohms nominal with 1578A accessory pre-amplifier (channel 1 or 2), Up to 50,000 ohms with 1579A accessory magnetic phono amplifier (channel 1 or 2), 600 to 15,000 ohms with 15095 accessory transformer (channel 1 or 2).	Ordering Information: Order one 361B amplifier plus the following: If 70-volt line output is required order one 16660 transformer. If volume compressor is required, order one 14678A assembly with 14722 mounting bracket. If accessory inputs are to be used, order any combination of the following: (two maximum may be used at any one time.) 1578A transistor preamplifier plug-in (microphone). 1579A equalized transistor phono preamplifier for magnetic phono pick-up. Plug-in. 1588A transistor preamplifier, plug-in, transformer-isolated input (microphone). 15095 transformer plug-in (high level balanced line to mixer). If rack mounting of the 361B mixer/power amplifier is desired order one 14965 rack mounting assembly. (Requires 5 1/4" of rack space.)
Load Impedance:	4/8/16 ohms. 275 ohms, ungrounded, with 16660 (70-v) transformer.	
Load Voltages:	8.5/12/14 volts. 70 volts, ungrounded, with 16660 transformer.	
Noise Level:	Equivalent input noise — -119 dbm with 1578A preamplifier. Output noise — -30 dbm with mixer controls closed (8 ohm load).	
Controls:	2 mixer, 1 tone, 1 power switch on front panel,	

ARCHITECTS AND ENGINEERS SPECIFICATIONS

The mixer/amplifier shall be self-contained and shall employ all solid-state devices. Without accessories, the mixer/amplifier shall be capable of mixing two independent input signals originating from either a ceramic phono pick-up, high-impedance microphone or equivalent, and from either a radio tuner, tape machine or equivalent. Either of the two inputs shall be capable of accepting 600-ohm low-impedance sources. Input connections shall be made in one of two ways: direct connections to terminal strips provided for the separate inputs, or, standard phono plugs for the high-impedance input, magnetic phono input and tuner input. The mixer/amplifier shall have separate volume controls on each input and shall have a treble tone control common to both inputs. In addition, each input shall have a socket provided for the use of various types of plug-in accessories, enabling the mixer/amplifier to accept signals from low-impedance sources, magnetic type pick-ups and bridged low-impedance lines.

The mixer/amplifier shall have a frequency response of ±1 db, 10-20,000 cps, and shall deliver 18 watts at less than 2% thd, (total harmonic distortion), 30-15,000 cps, to a 4/8 ohm load. The output of the mixer/amplifier shall be of the transformerless type, capable of delivering 25 watts into loads ranging from 4 to 6 ohms. The output shall be capable of operating a 70-volt transformer for standard speaker distribution systems, and the 70-volt transformer accessory, specified elsewhere, shall be mounted on the rear of the mixer/amplifier and shall connect to the mixer/amplifier without the need of soldering, utilizing interconnecting links supplied with the transformer.

The mixer/amplifier shall provide operating voltages and a connecting socket for a compressor assembly accessory, specified elsewhere, which may be mounted to the rear of the unit, to provide volume compression when required.

The mixer/amplifier shall have a self-contained power supply, operating from 120 vac, (requiring no more than 42 watts when delivering full power), and shall have self-resetting circuit breakers in both the primary and the transistor supply circuits. Fuse or manual resetting devices are not acceptable.

The mixer/amplifier shall measure no more than 4 3/4" high, 13 3/4" wide, and 8 1/4" deep. It shall weigh no more than 10 pounds and shall be dark green in color.

There shall be available, as a plug-in accessory to the mixer/amplifier, a transistor preamplifier with a nominal 150-ohm source impedance, usable 30-20,000 ohms. Frequency response shall be ±0.5 db, 20-20,000 cps, or ±1.5 db, 15-50,000 cps. The transistor plug-in preamplifier shall have a gain of 33.5 db and sensitivity shall be 43 millivolts for an output of +8 dbm. The plug-in transistor preamplifier shall allow any high-quality low-impedance microphone to be used with the mixer/amplifier.

There shall be available, as a plug-in accessory to the mixer/amplifier, a phono equalized transistor amplifier which shall meet the RIAA standard. Sensitivity shall be 5 millivolts for 70-millivolt output at 1 kc. Output shall be +8 dbm at less than 0.5% thd (total harmonic distortion). Input impedance shall be 47,000 ohms and power required shall be 12 vdc at 11 ma.

There shall be available, as a plug-in accessory to the mixer/amplifier, a transistor preamplifier with a transformer-isolated input and with a nominal 150-ohm source impedance, usable 30-20,000 ohms. Frequency response shall be ±1 db, 30-30,000 cps. The transistor plug-in preamplifier shall have a gain of 33.5 db and sensitivity shall be 43 millivolts for an output of +8 dbm. The plug-in transistor preamplifier shall allow any high quality low impedance microphone to be used with the mixer/amplifier.

Any mixer/amplifier and plug-in accessories not meeting the above specifications shall be deemed unacceptable under this specification.

The mixer/amplifier shall be Altec Lansing model 361B.

The transistor preamplifier shall be Altec Lansing model 1578A.

The phono preamplifier shall be Altec Lansing model 1579A.

The transistor preamplifier with transformer-isolated input shall be Altec Lansing model 1588A.

NOTICE

We recommend that you obtain your Altec products from factory trained authorized Altec Sound Contractors and Distributors. This will assure you of proper installation, a continuing source of knowledgeable advice, service, and quick warranty protection.